



Current and Future Challenges in Automotive EMC

Dr. Marco KLINGLER

EMC Expert

Stellantis

Vélizy-Villacoublay, France

marco.klingler@stellantis.com

Overview

- Introduction and background
 - Automotive external electric / electromagnetic environment
 - Automotive EMC requirements

- The mobility themes and topics impacting automotive EMC
 - Reduction of CO₂ emissions
 - Connectivity
 - Advanced Driver Assistance Systems (ADAS) and Autonomous / automated vehicles

- Conclusions and perspectives



Introduction and background

Automotive external electric / electromagnetic environment

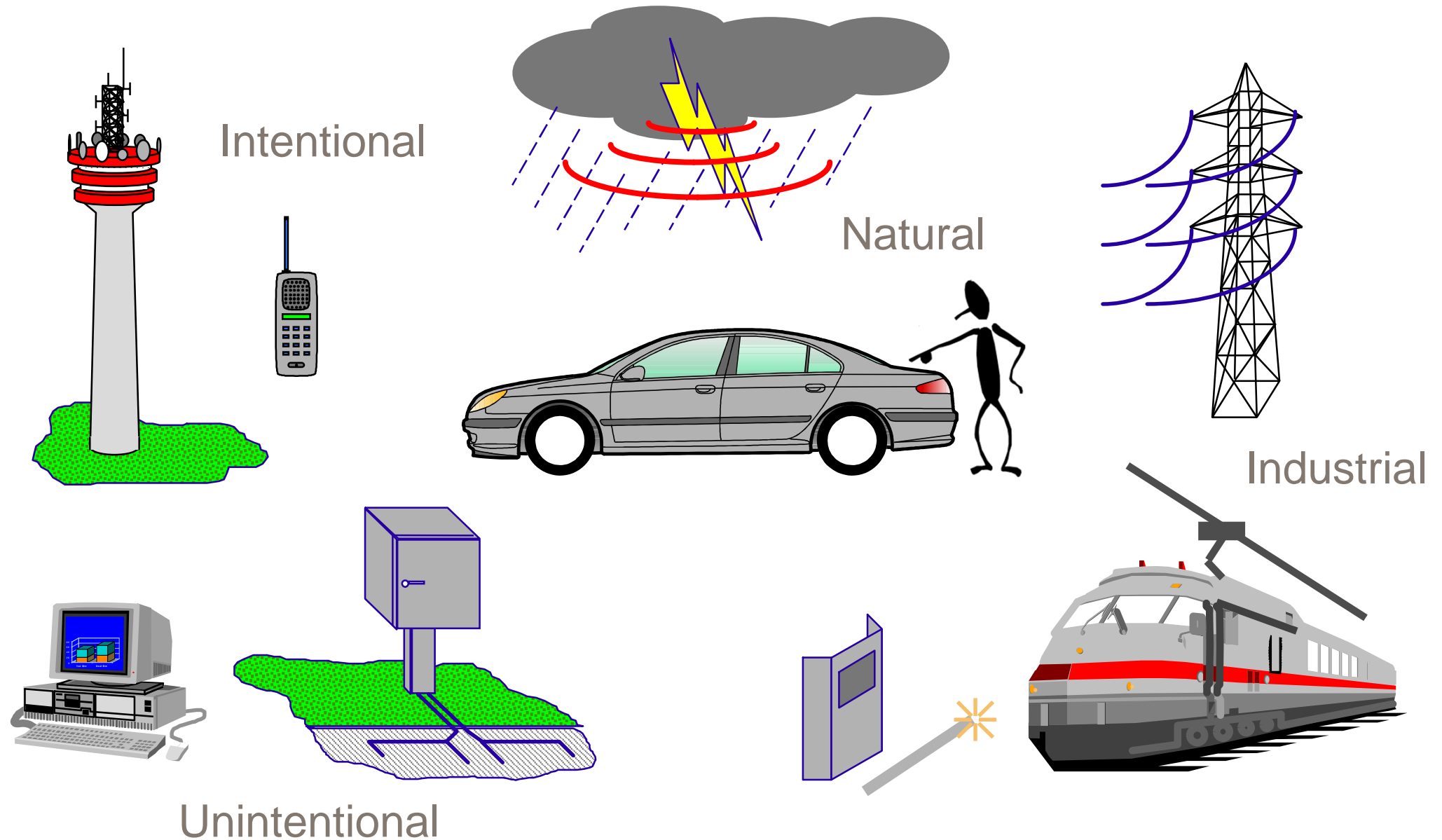

Automotive EMC requirements (1)

Radiated immunity to external sources

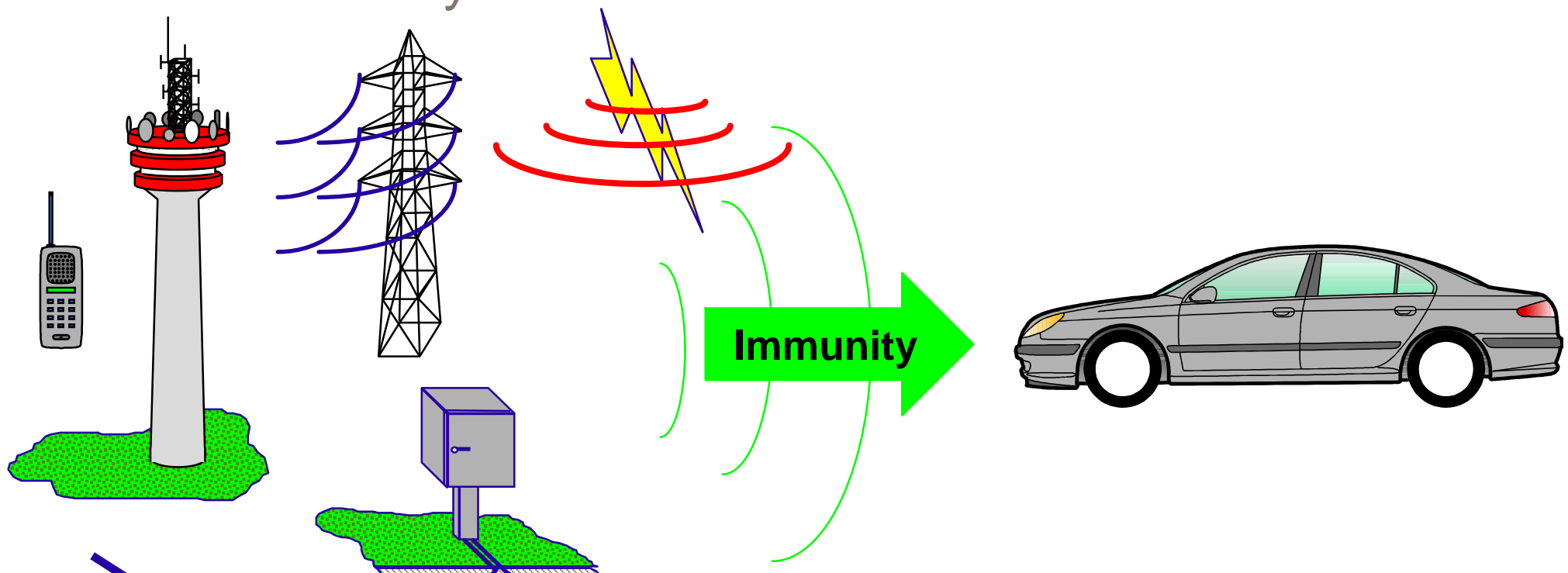

- The EE⁽¹⁾ systems of the vehicle must not be disturbed by its environment
- Validation and **type approval / homologation (ECE R10)** requirements

(1) Electric / electronic

Automotive EMC requirements (2)

External radiated emission

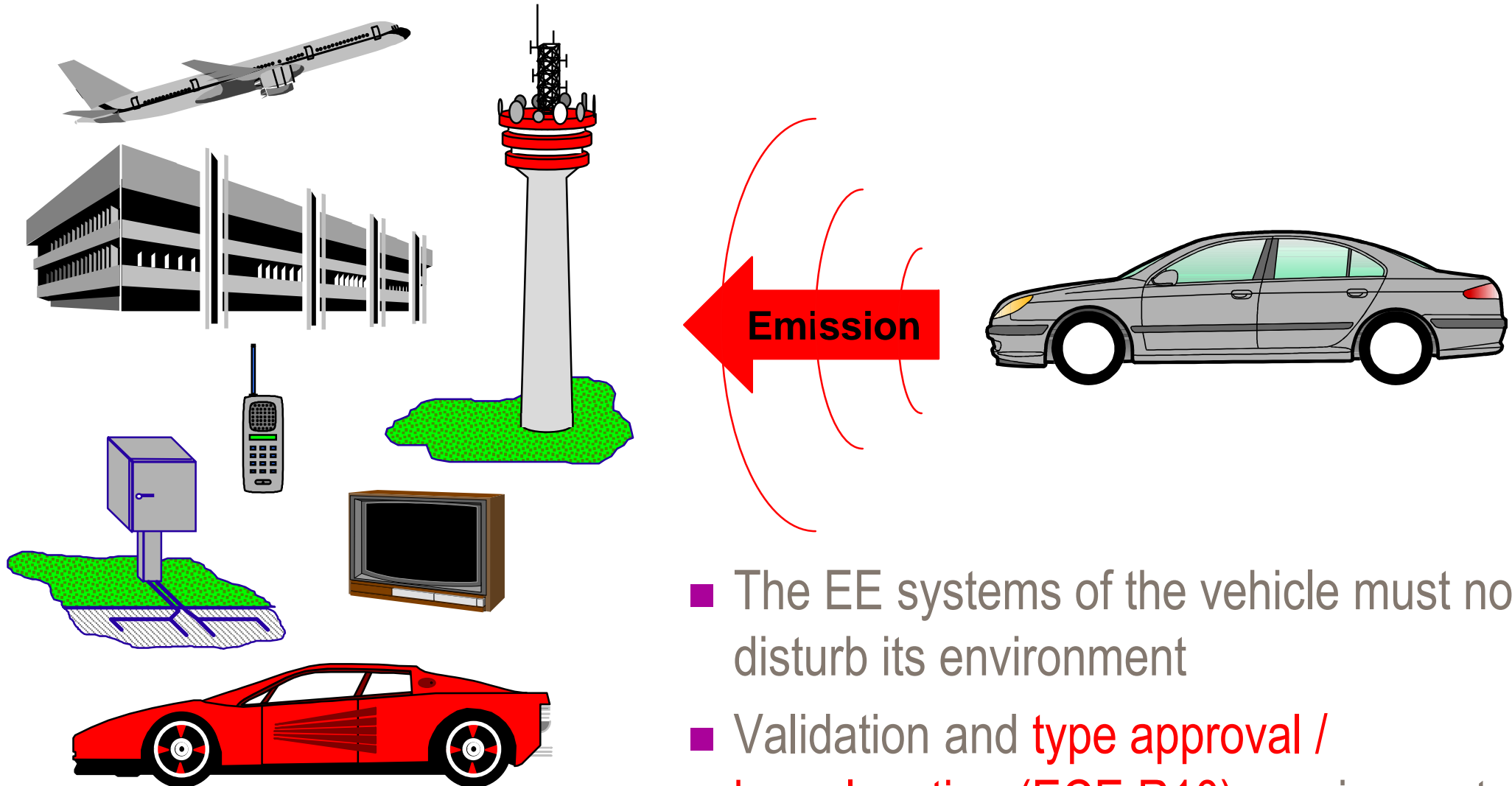

- The EE systems of the vehicle must not disturb its environment
- Validation and **type approval / homologation (ECE R10)** requirements

Automotive EMC requirements (3)

Human exposure / health protection

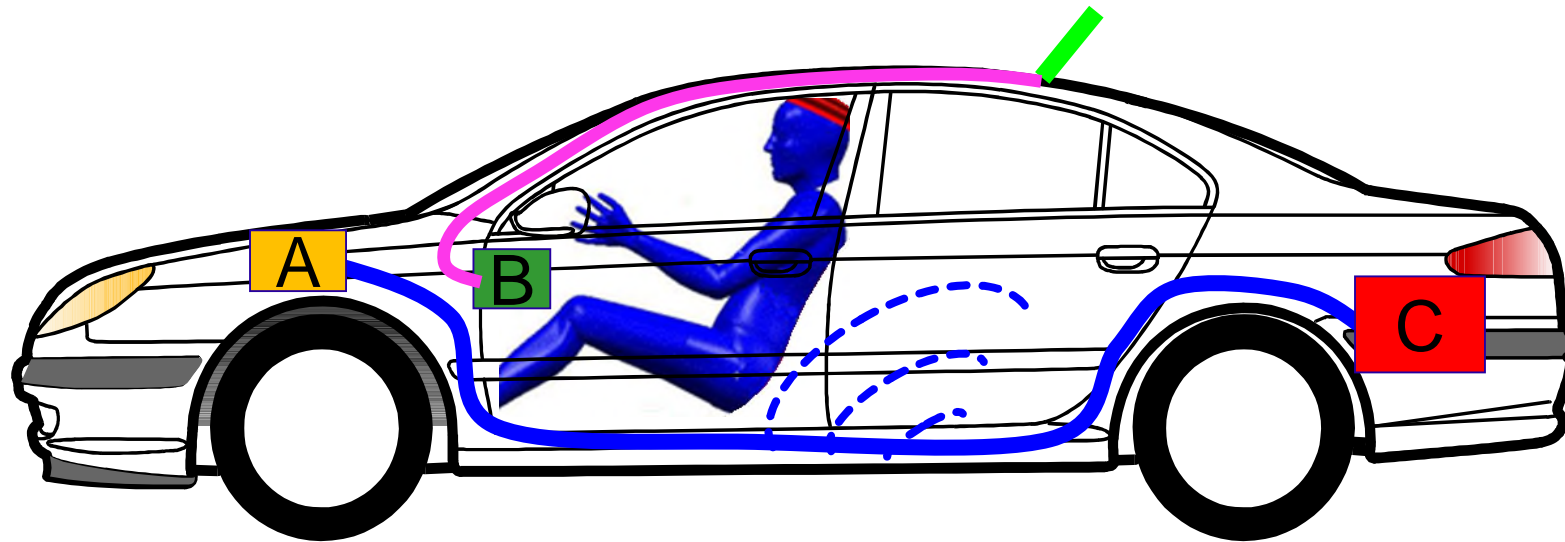

- The electric and magnetic radiated fields by the EE systems of the vehicle must not exceed defined maximum levels
- Validation and **EU recommendation 1999/519/EC (based on ICNIRP)** requirements

Automotive EMC requirements (4)

Radiated immunity to onboard transmitters

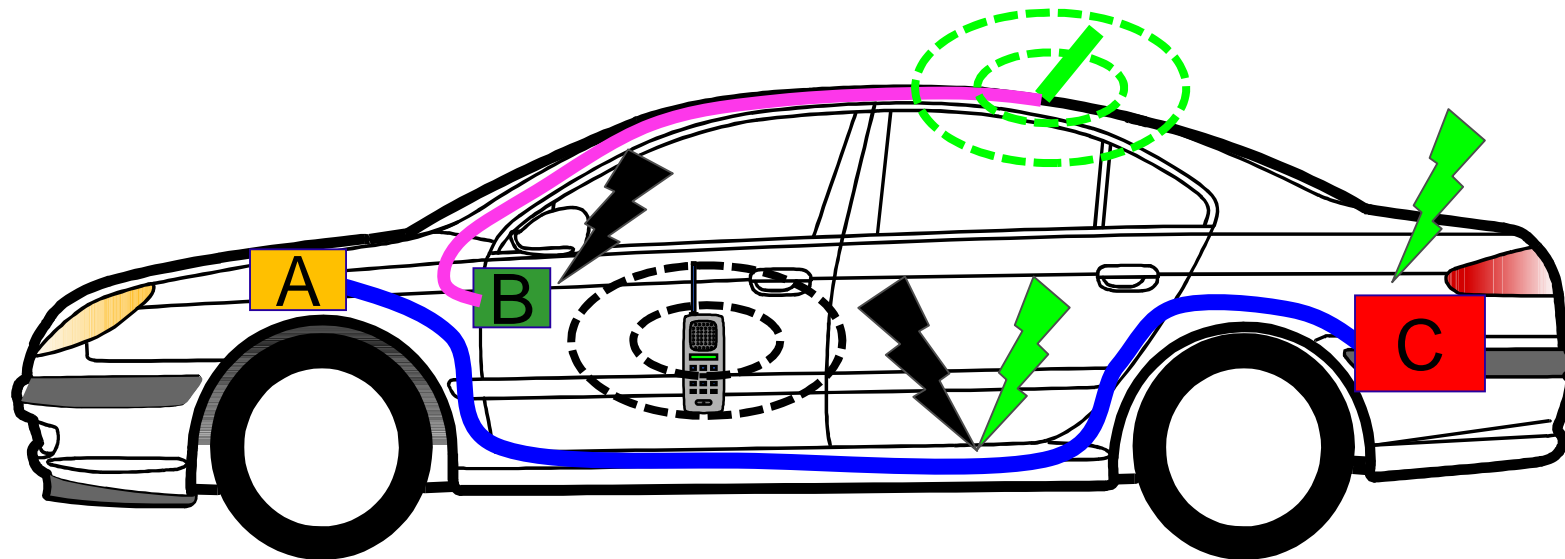

- The onboard transmitters, mobile or fixed, pre-installed or aftermarket, should not disturb the equipment of the EE systems of the vehicle
- Validation requirement

Automotive EMC requirements (5)

Intra-compatibility

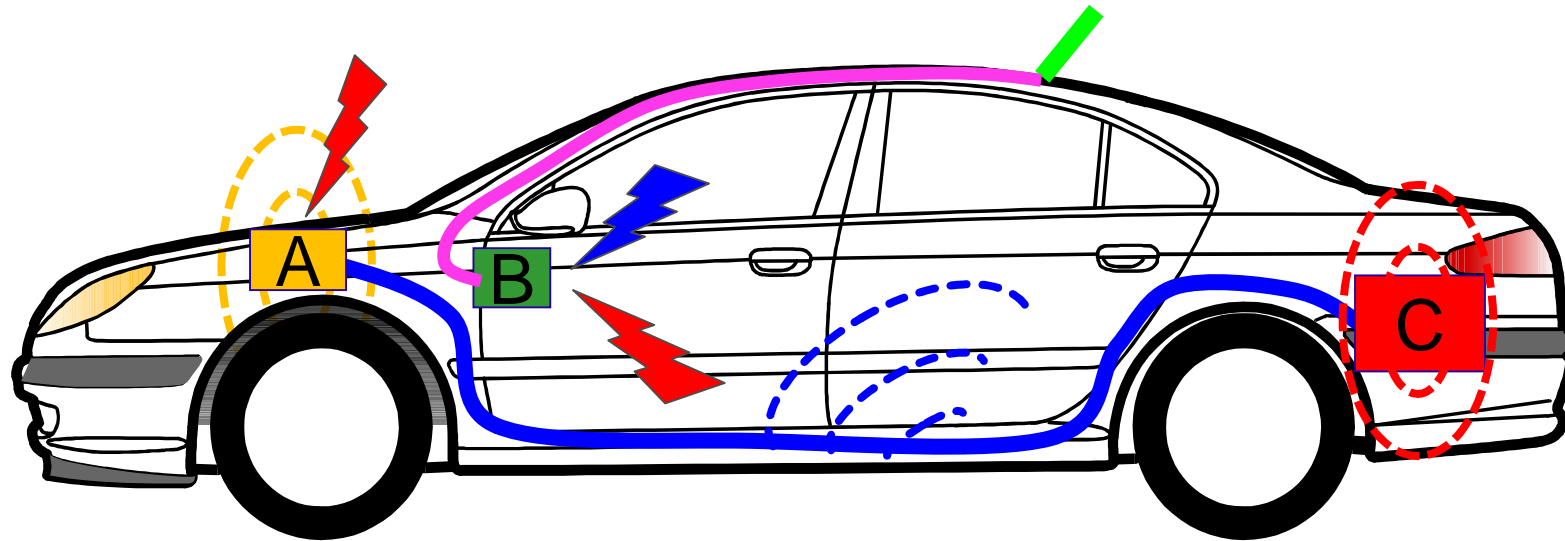

- The equipment of the EE systems of the vehicle should not disturb one other
- Validation requirement

Automotive EMC requirements (6)

Protection of the radio reception

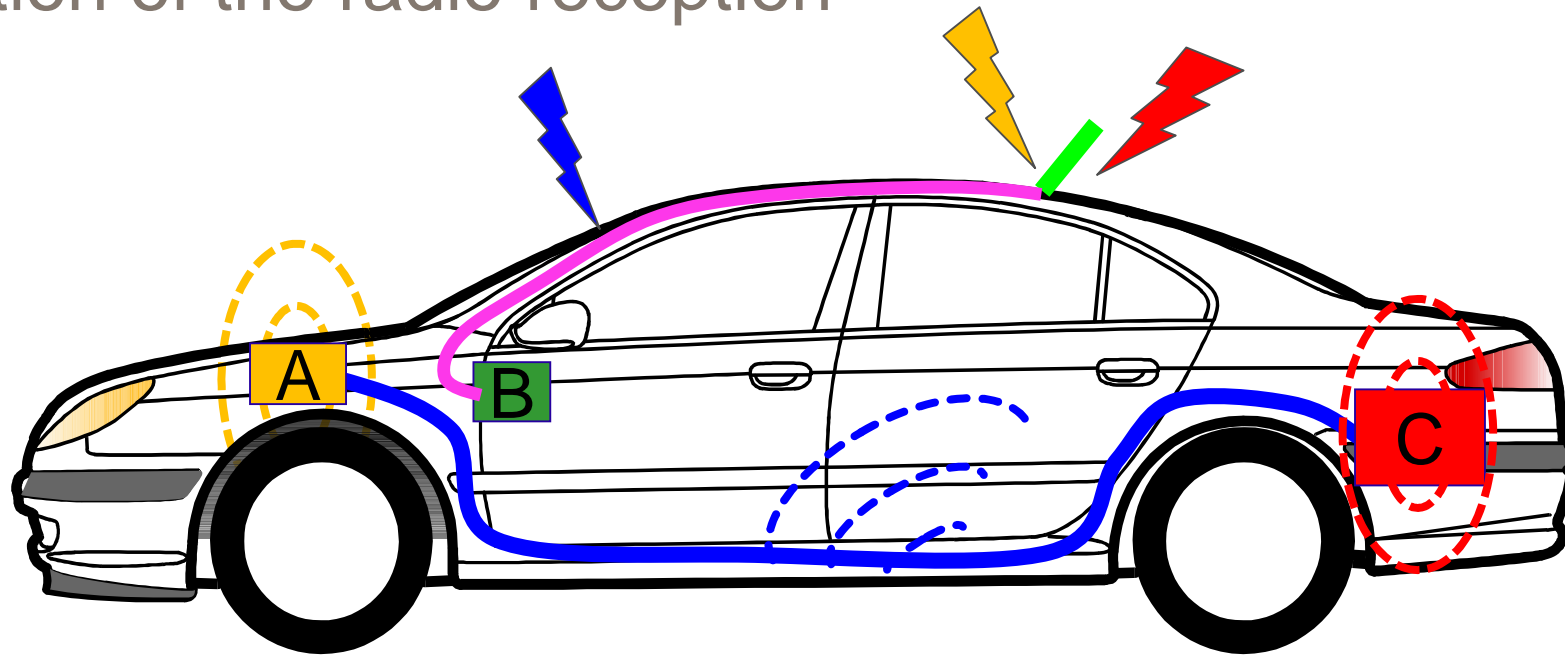

- The EE systems of the vehicle should not create disturbances on the antenna inputs of the radio-communication equipment of the vehicle (car radio, emergency call module, GPS, etc.)
- Validation requirement (disturbance voltage at receiver antenna terminal)

Automotive EMC requirements (7)

Residential, commercial and light-industrial environments

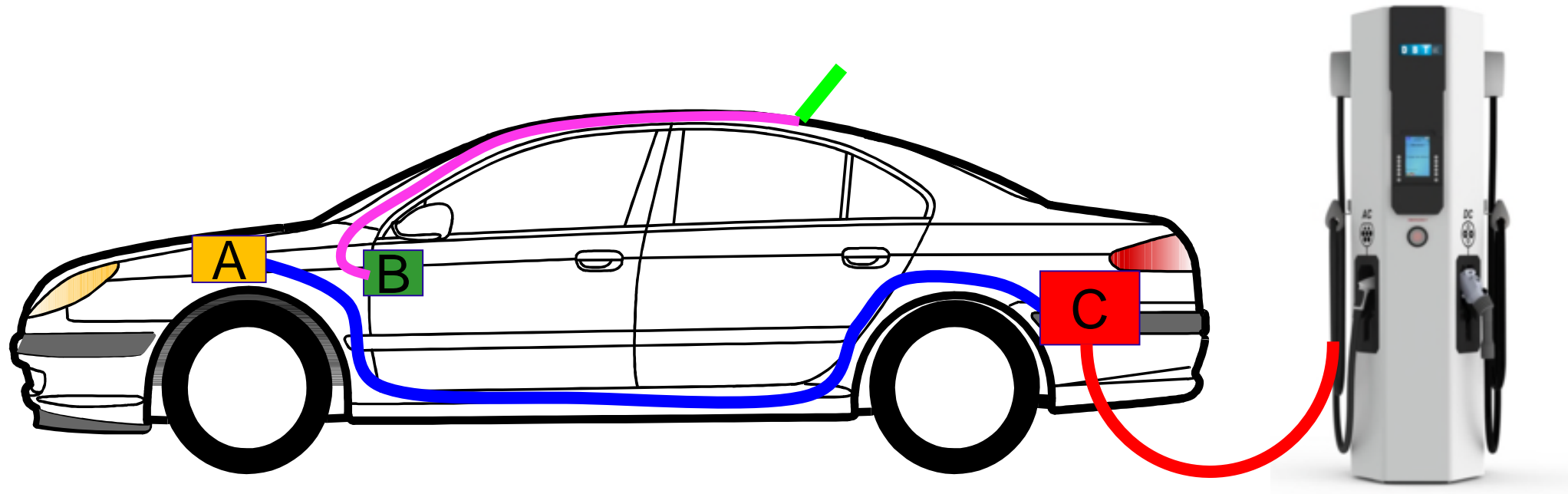

- Only for plug-in electric or hybrid vehicles
- Radiated immunity and emission + conducted immunity (fast transient /bursts) and emission (harmonics, voltage changes, flicker noise)
- Validation and **type approval / homologation (ECE R10)** requirements

Automotive EMC requirements (8)

Protection against electrostatic discharges (ESD)

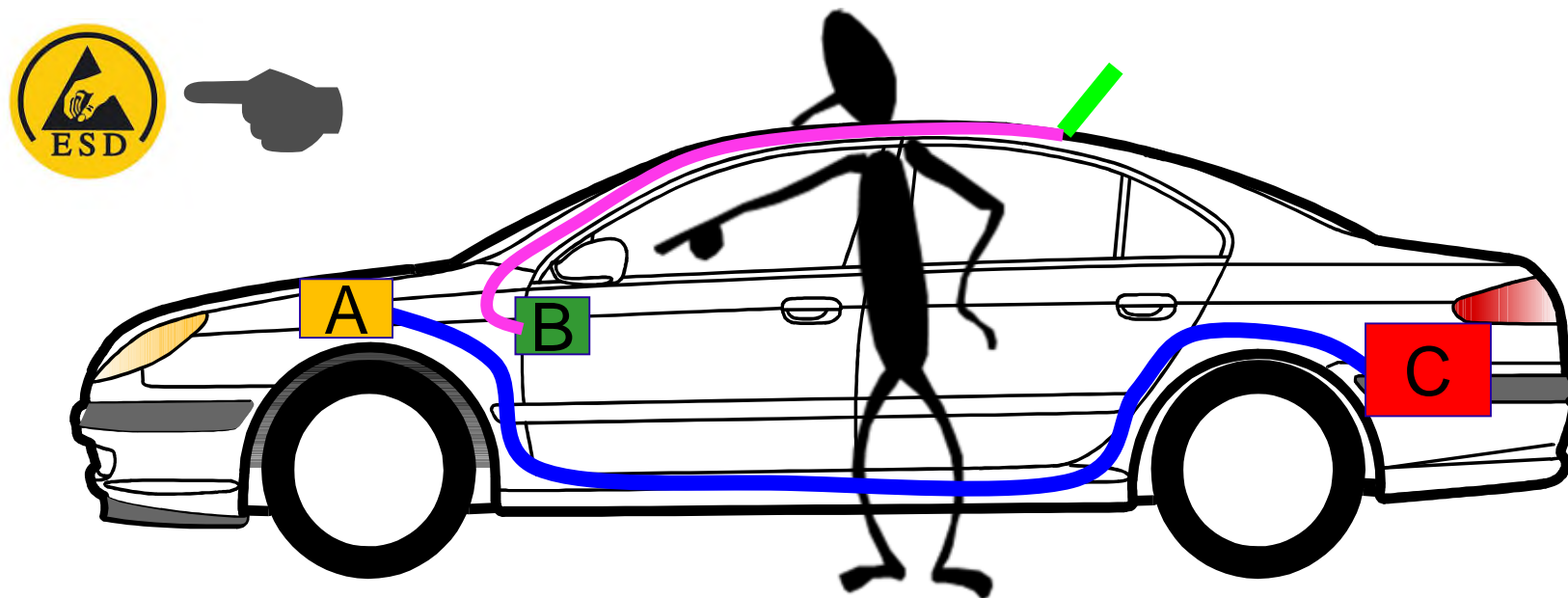

- The equipment of the EE systems should not be disturbed or destroyed by direct or indirect electrostatic discharges (ESD)
- Validation requirement

The mobility themes and topics impacting automotive EMC

- Reduction of CO₂ emissions
 - Electric and full-hybrid vehicles
 - 48V powertrains
 - Battery electric vehicles or plug-in hybrid electric vehicles in charging mode
 - Wireless power transfer systems
 - Composite materials
- Connectivity
 - Digital audio broadcasting reception
 - In-vehicle high data rate wire link
 - Wireless communications
 - In-vehicle wireless charging
- Advanced Driver Assistance Systems (ADAS) and autonomous / automated vehicles



Reduction of CO₂ emissions

Electric and full-hybrid vehicles (1)

■ Description

- Electric powertrain already developed and marketed
 - 200V to 800V / $\approx 30\text{kW}$ to $\approx 200\text{kW}$
- HV electric system must comply with mandatory electrical safety requirements ($> 60\text{V}$)
 - Electrical isolation within the components
 - Electrical isolation with the car body
 - No power return currents via the metallic chassis
- Other power electrical appliances connected to the HV network
 - Air-conditioning compressor, heating resistances, ...
- New transistor technologies (SiC)
 - Increase of switching frequency
 - Decrease of the rise / fall times
- New generation of powertrains
 - Removable range extender (battery pack inside a trailer)
 - Distributed electric motors (in wheels)

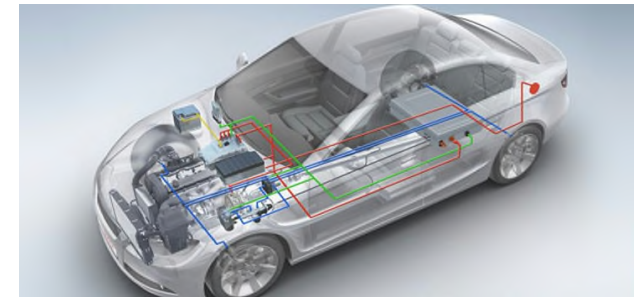

Electric powertrain
(www.bosch.com)



Hybrid electric powertrain
(lotusproactive.com)

Electric and full-hybrid vehicles (2)

■ EMC issues

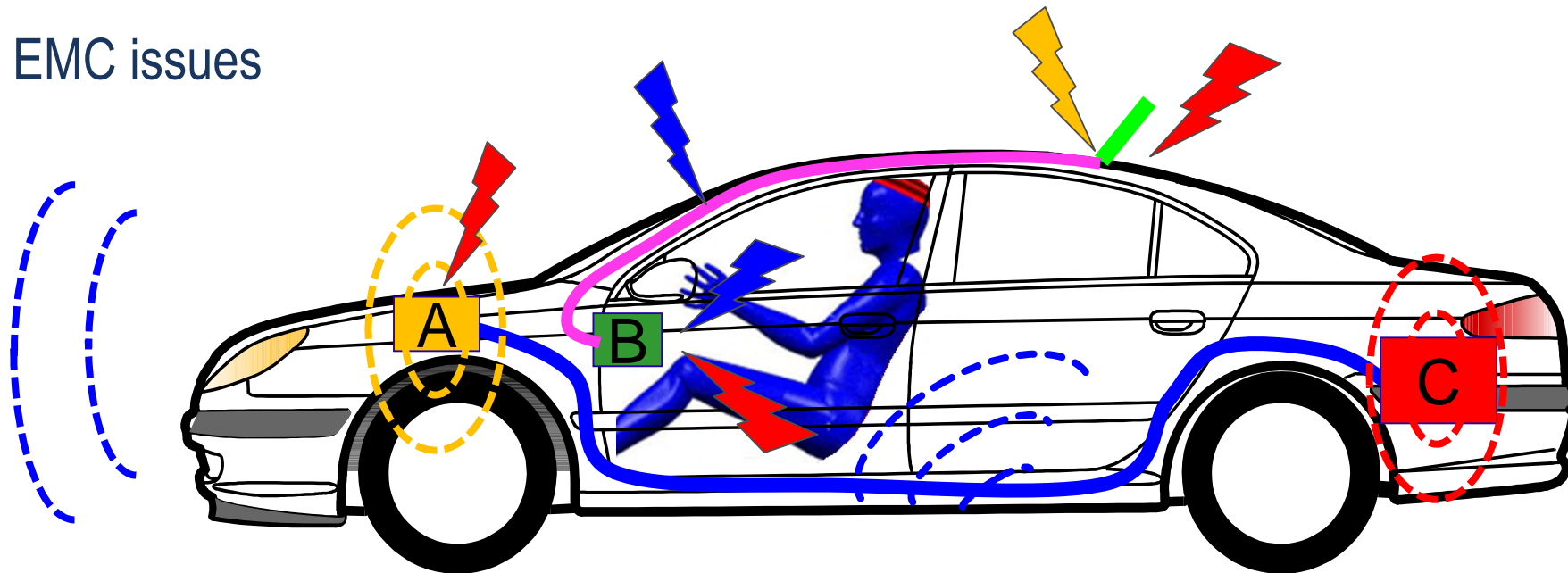

- Radiated **emissions** (wider and higher spectrum and higher level of harmonics)
- Disturbance voltage at receiver antenna terminal → **quality of radio reception** (with more challenges in AM bands)
- **Health protection**
 - Radiated magnetic fields for power cables and connectors
- **Intra-compatibility** (radiated and conducted)

48V powertrains (1)

■ Description

- Target: **weight / cost reduction of future powertrains**
- Electric motors from ≈ 6 kW to ≈ 20 kW
- **Higher level of currents than full-hybrid vehicles** (practically the same as for electric vehicles)
- **Other power electrical appliances connected to the power network** :Air-conditioning compressor, heating resistances, ...
- No mandatory electrical safety requirements
 - **Non-isolated power circuit**
 - No electrical isolation within the components
 - **Functional return current through the car body** possible for the electrical department
 - **More consequent EMC arbitration regarding cost considerations**

■ EMC issues

- Same type of issues **as previously but more severe**



48V system demonstrator vehicle
(m.schaeffler.com)



48V Motor Drive System
(www.electricmotorsport.com)

BEV or Plug-in HEV in charging mode (1)

■ Description

- Battery-powered full electric or hybrid electric vehicles are plugged to the power grid to charge their batteries
- Different charging modes exist depending on:
 - The kind of charging station
 - The technology of the charger of the car
- Pre-heating of the car is possible (can be planned from an iPhone or a pilot wire)
- Many different topologies of power converter are possible, depending on:
 - Charging mode and power rate
 - Cost target
 - Available space for integration / filtering / shielding
- Bi-directional charger technology makes it possible to develop V2H or V2G applications
- Power line communication (PLC) is used in the V2H/V2G scenario for data exchange



Charging modes according to standard IEC 61851-1

Picture from E.J. Dede, GH Group, PCIM 2014



(www.hitachi.com)

BEV or Plug-in HEV in charging mode (2)

■ EMC issues

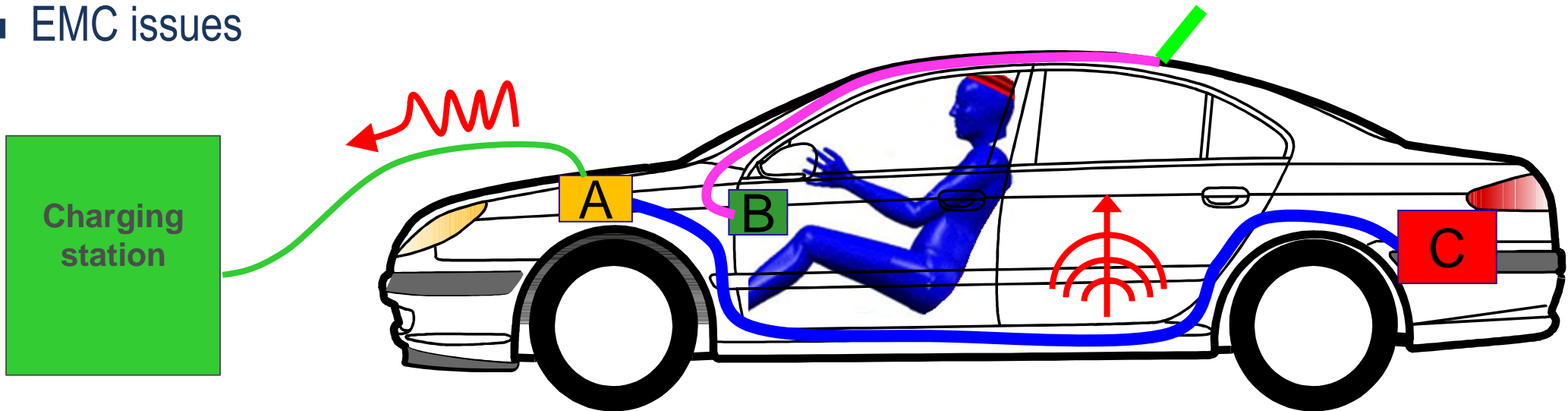

- From in-vehicle embedded electronics to the world of “plugged commercial appliances”
- New EMC requirements unusual to the automotive world shall be taken into account
- Smart Grid: EMC compliance and high-quality power factor in all situations won't be negotiable

Wireless Power Transfer systems (1)

■ Description

- **Wireless power transfer (WPT) by LF magnetic flux** (81kHz to 90kHz, central frequency 85 kHz)
- Different classes of power (3,7kW to 22kW)
- Compatibility between automotive systems and infrastructures systems
- **Alignment of the magnetic coils**
- Functional and operating modes are not well known and definitely defined (ongoing standardization, IEC 61980)
- **Fixed or adjustable frequencies**
- **Wireless charging while cruising** (under research)



A wireless charging system
(www.designworldonline.com)



A wireless charging system for vehicles
(www.autoweek.com)

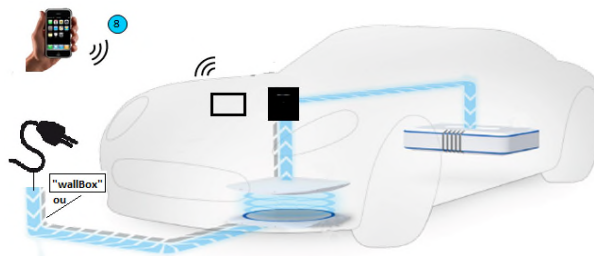

Static charging system for vehicles

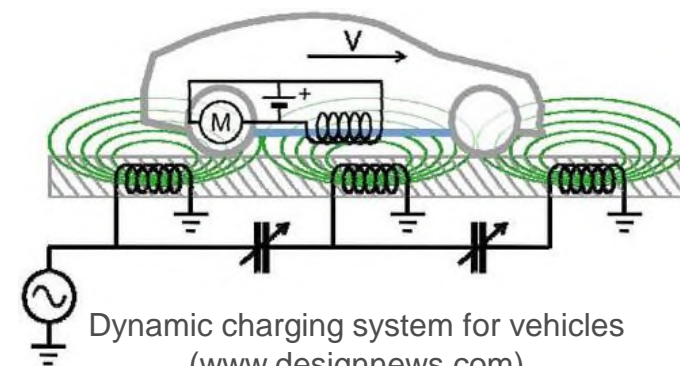

Dynamic charging system for vehicles
(www.designnews.com)

Wireless Power Transfer systems (2)

■ EMC issues

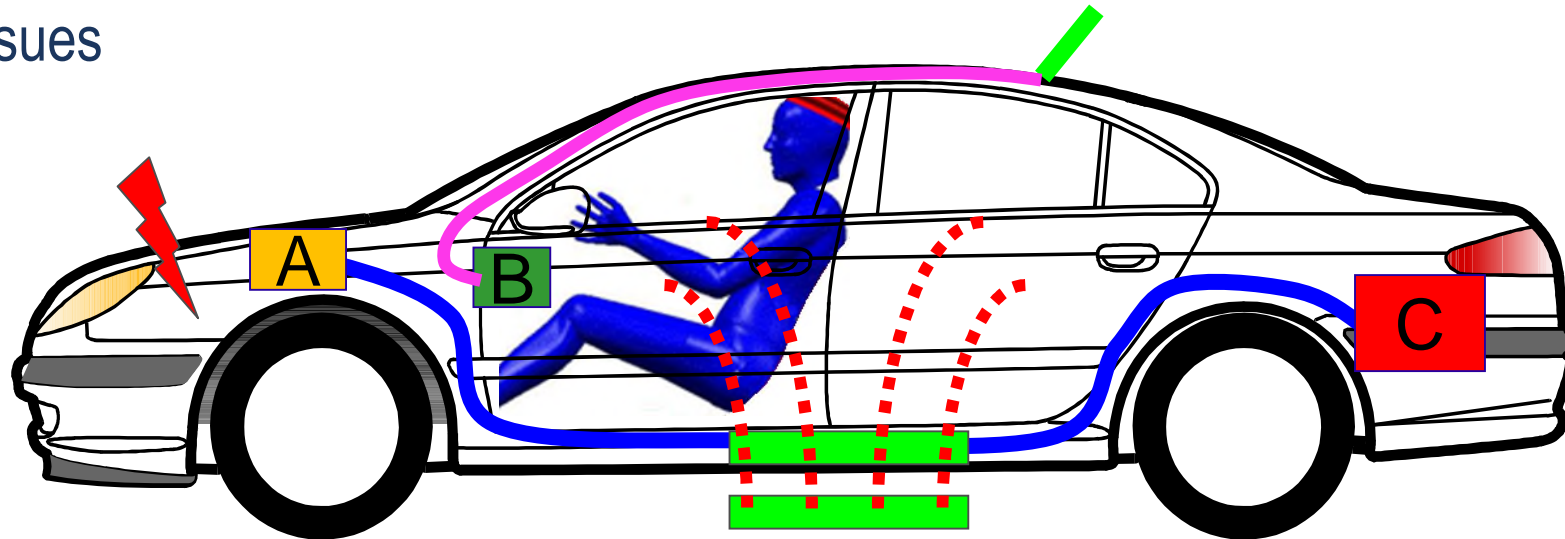

- Health protection (in and in the vicinity of the vehicles)
 - Intentional radiated magnetic fields
 - Unintentional electric fields
- Immunity / disturbances of various type of magnetic sensors of the vehicle
- Disturbance of Smart keyless entry and start systems at 125 kHz

Composite materials (1)

■ Description

- Used for the **structure**, the reinforcements, the openings (doors, etc.), the housing of components
- Composed of a **reinforcement** which handles the mechanical characteristics and a **matrix** which acts as a paste
- Unusual characteristics obtained by **association** of the matrix and the reinforcement materials
- **Metallic matrices** (Aluminum, Magnesium or Titanium alloys). Reinforcement: Carbon, silicon carbide (SiC), alumina
- **Ceramic matrices** (Carbon, SiC). Reinforcement: Carbon
- **Organic matrices** (polymers, plastics). Reinforcement: Carbon, glass, aramid, SiC, basalt, bore ...
- From an electric / EM point of view:
 - **Non-conductive** (fiberglass, etc.)
 - **More or less conductive** (carbon fiber)

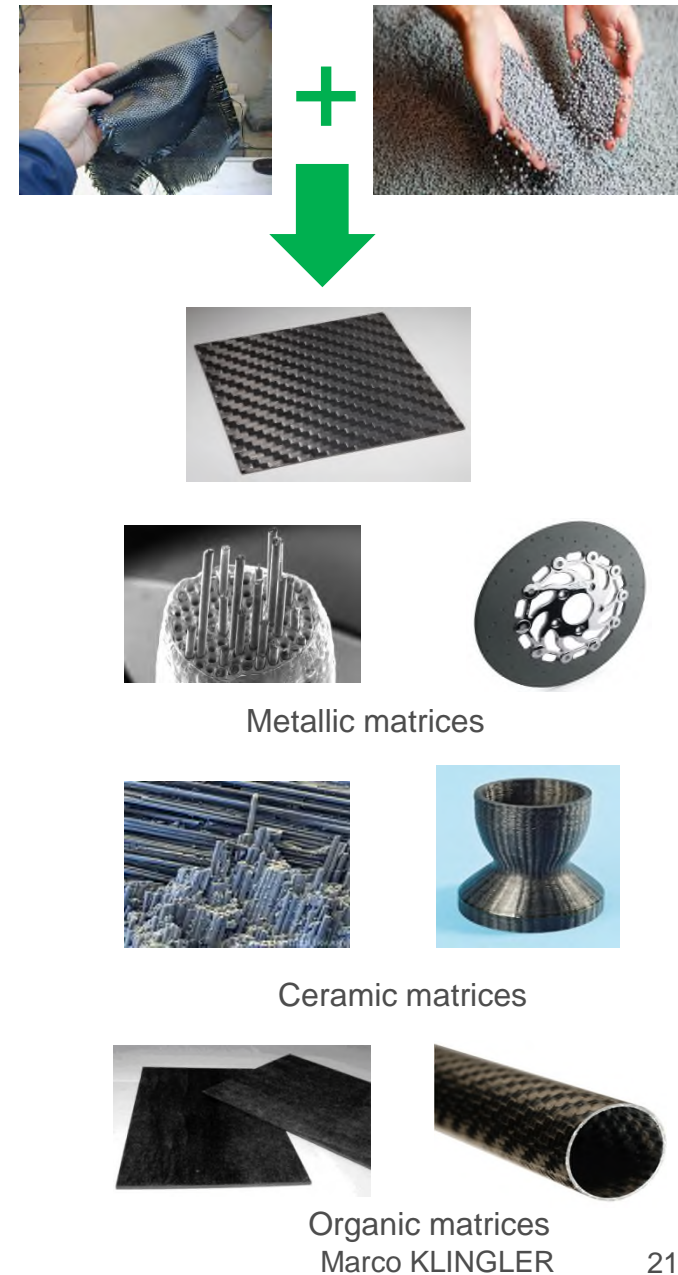

Composite materials (2)

■ EMC issues

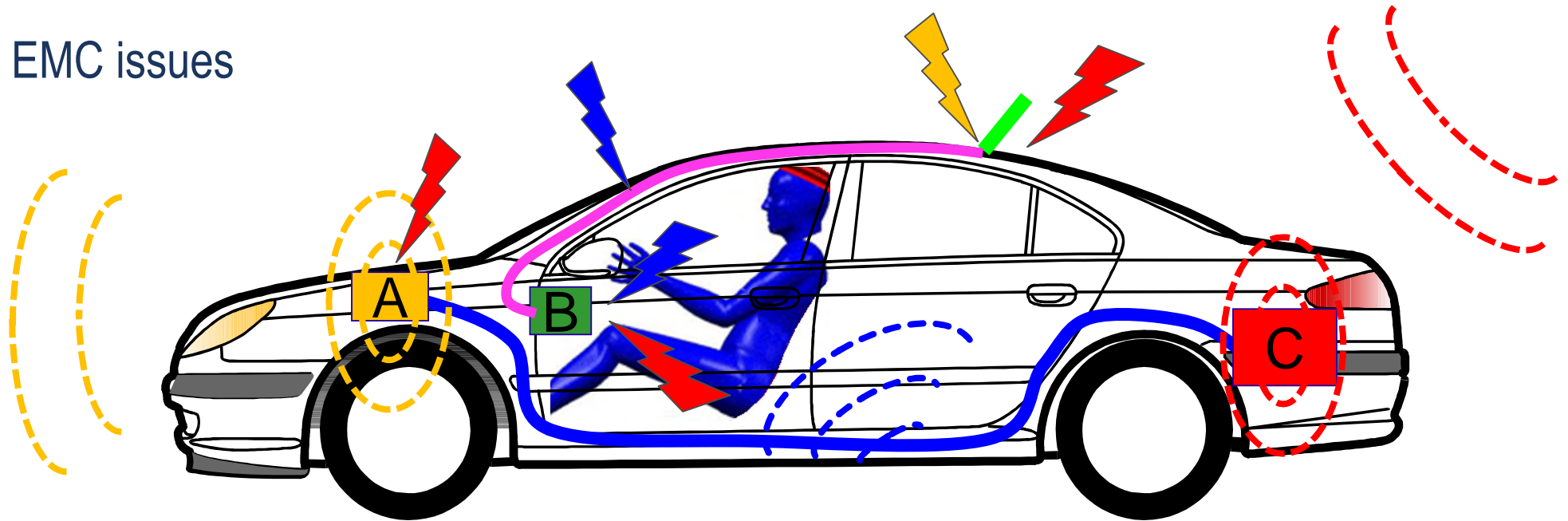

- Modification of the “ground” reference for the electrical system and the antennas
- Modification of the return current paths (functional and disturbances)
 - Radiated immunity to external sources and to on-board transmitters
 - Radiated emissions towards external environment
 - Human exposure / Health protection
 - Intra-compatibility
 - Disturbance voltage at receiver antenna terminal (quality of radio reception)



Connectivity

Digital audio broadcasting reception (1)

■ Description

- Analog FM radio broadcasting (76MHz – 108MHz) is progressively being replaced by digital broadcasting (already operational in countries)
- **DQPSK** (Differential Quaternary/Quadrature Phase-Shift Keying) modulation
- 2 frequency bands:
 - **DAB III** (174.928 MHz – 239.200 MHz) : 38 blocs
 - **DAB L** (1452.960 MHz – 1478.640 MHz) : 16 blocs
- Bloc bandwidth 1.536 MHz
- 1536 sub-carriers per bloc (every 1 kHz)
- One bloc can contain several data radio stations and data channels (up to 10 radio stations)



(www.mp3car.com)

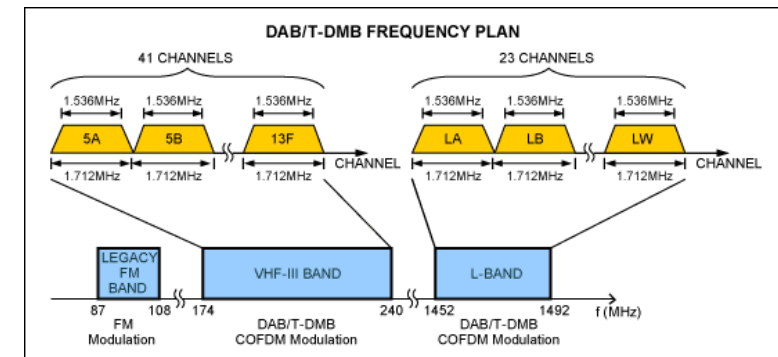

Intelligent Antenna Module
(www.kathrein.de)

Digital audio broadcasting reception (2)

- EMC issues

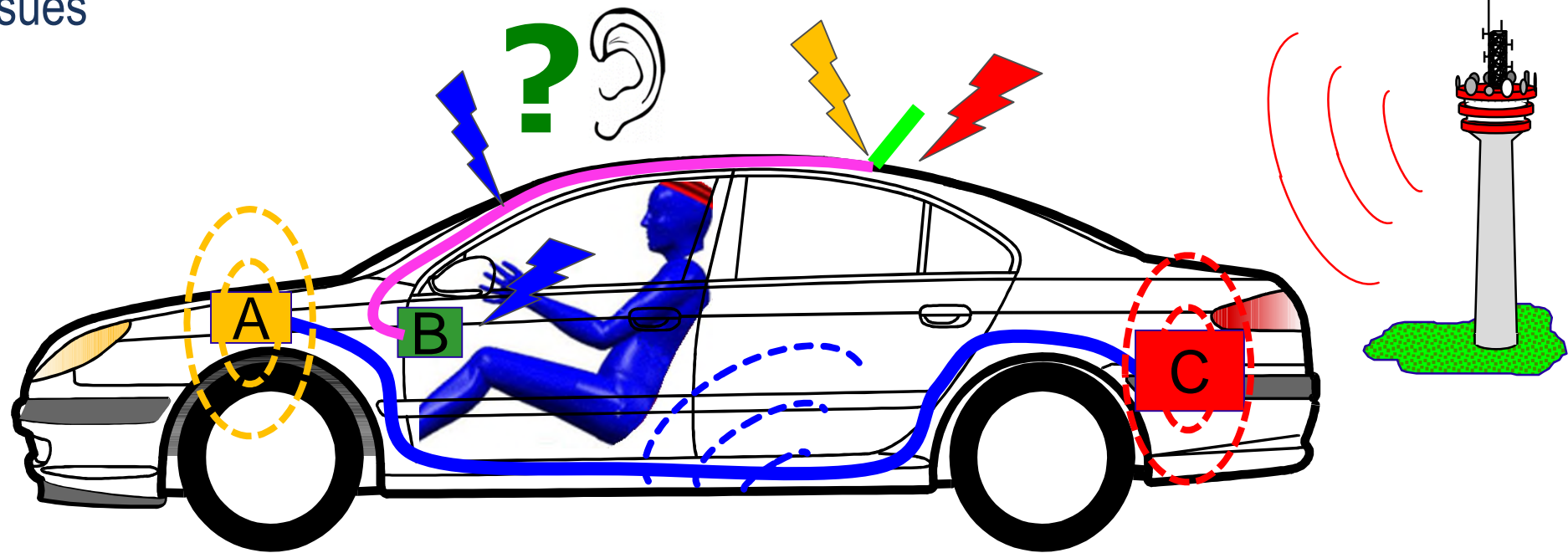

- Disturbance voltage at receiver antenna terminal → quality of radio reception

In-vehicle high data rate wire link (1)

■ Description

- **LIN** (Local Interconnect Network)
 - Up to **20 kbps**, master/slave system
- **CAN** (Controller Area Network)
 - CAN-B at **125 kbps**, CAN-C at **1 Mbps**, CAN-FD at **2 Mbps**
- **FlexRay**
 - Redundant and time-controlled (deterministic)
 - Up to **10 Mbps** (x2 if 2 channels without redundancy)
- **MOST** (Media Oriented Systems Transport)
 - Up to **150 Mbps**, ring network, optical fiber
- **LVDS** (Low-Voltage Differential Signaling) at **3, 125 or 6 Gbps**
- **Open Alliance** framework and IEEE 802.3pb standard
 - **100 Mbps** embedded Ethernet on a **single unshielded twisted pair**
 - Next generations at **1 Gbps, 5 Gbps**
 - Architectural flexibility for multiple applications
 - Typical application: **ADAS systems** (*described later*)
 - Plug & play low-cost architecture to cover all configurations



(www.delphi.com)

OPEN
ALLIANCE

BroadR-Reach® Ethernet Technology

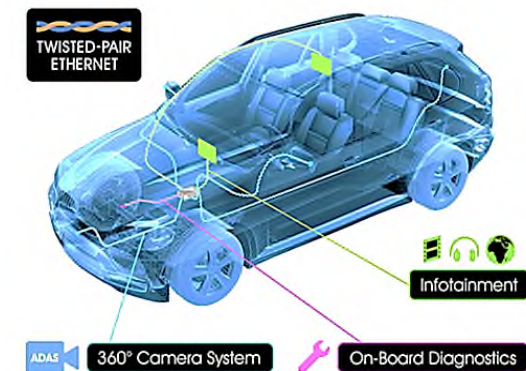

(www.opensig.org)

In-vehicle high data rate wire link (2)

■ EMC issues

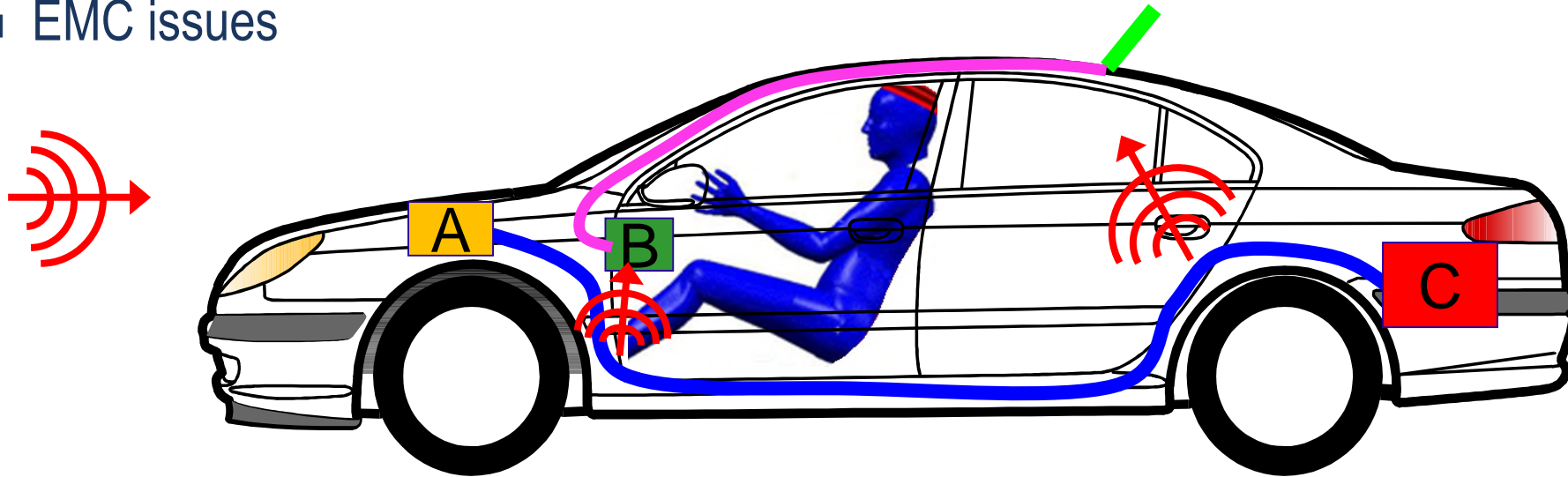

- Disturbance voltage at receiver antenna terminal (**resonances** the network of shielded links and 0V wires) → **quality of radio reception**
- **Radiated immunity** (external sources, on-board transmitters)
- **Intra-vehicle compatibility** (crosstalk and common mode impedance coupling)

Wireless communications (1)

■ Description

■ Within the vehicle

- Smart keyless entry and start system, Tire Pressure Monitoring System, Bluetooth, WiFi hotspot

■ RFID (up to 10m range)

- Parking lot control, Car manufacturing tracking

■ Between the car and the environment - reception only

- AM, FM, DAB, Digital Video Broadcasting Terrestrial (DVB-T), Satellite Digital Audio Radio Service (SDARS)
- Navigation systems GPS and GLONASS

■ Between the car and the environment - connectivity

- 2G, GSM, GSM/DCS, Emergency-call
- 3G Universal Mobile Telecommunication System (UMTS)
- Long Term Evolution (LTE): 4G, 5G, 5G+ ...
- C2X (car to car & car to infrastructure) for Intelligent Transportation Systems (ITS) – “Always connected”
- Dedicated Short Range Communication devices (DSRC)
- Low Earth Orbit (LEO) Satellites: Rx \approx 19GHz, Tx \approx 29GHz

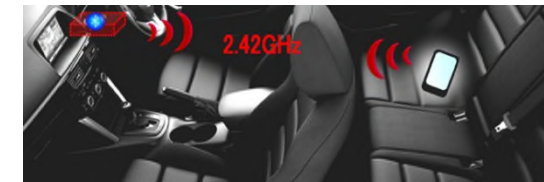
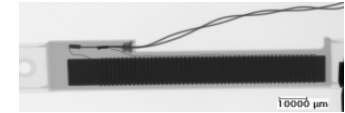

(www.advantech.com)



(www.delphi.com)



(www.dot.gov)

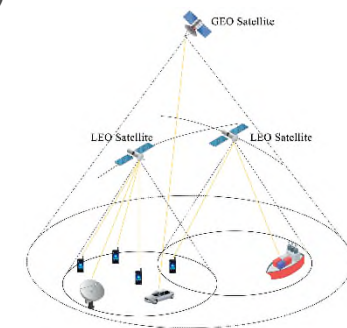

(www.mdpi.com)

Wireless communications (2)

■ EMC issues

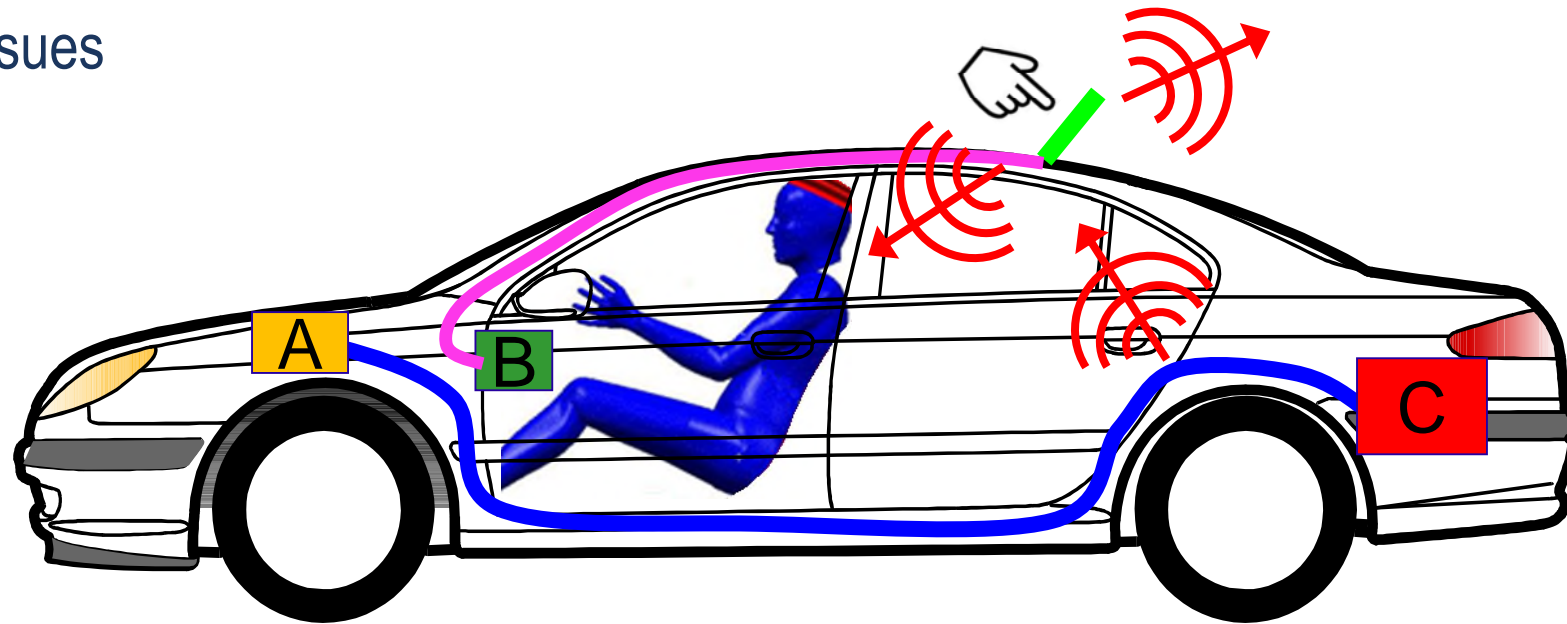

- Compatibility between the transmitter emission level and in-vehicle electronics
- Immunity of all communication receivers to unintentional emissions from the car electronics
- Intentional malicious attacks (radio jamming, etc.)
- Health protection
 - Human exposure to EM field from intra- and extra- embedded antennas
 - Now covered by the Radio Equipment Directive (RED 2014/53/UE) for SAR

In-vehicle wireless charging (1)

■ Description

- Wireless **charging system for mobile devices** (mobile phones, pads, laptops ...)
- No more mess in the cabin (cords, plugs, adaptors...)
- More environmental-friendly (no more need for and disposal of adaptors)
- Stylish cradle or pad stations
- **Several possible power rates** (from mW to some W)
- Typical **working frequency in the range from 100 kHz to 200 kHz**
- **Next step : « truly wireless experience »**, electric power transfer over the cabin from one single resonant transmitter, without any contact



(www.wirelesspowerconsortium.com)



(www.delphi.com)

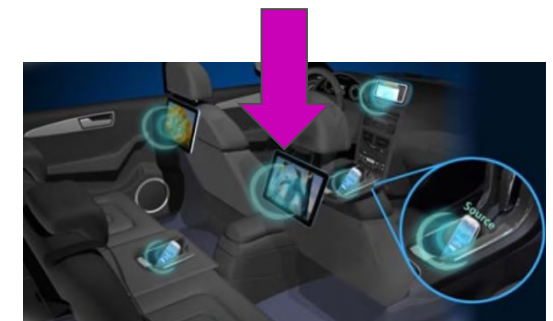

In-vehicle wireless charging (2)

- EMC issues

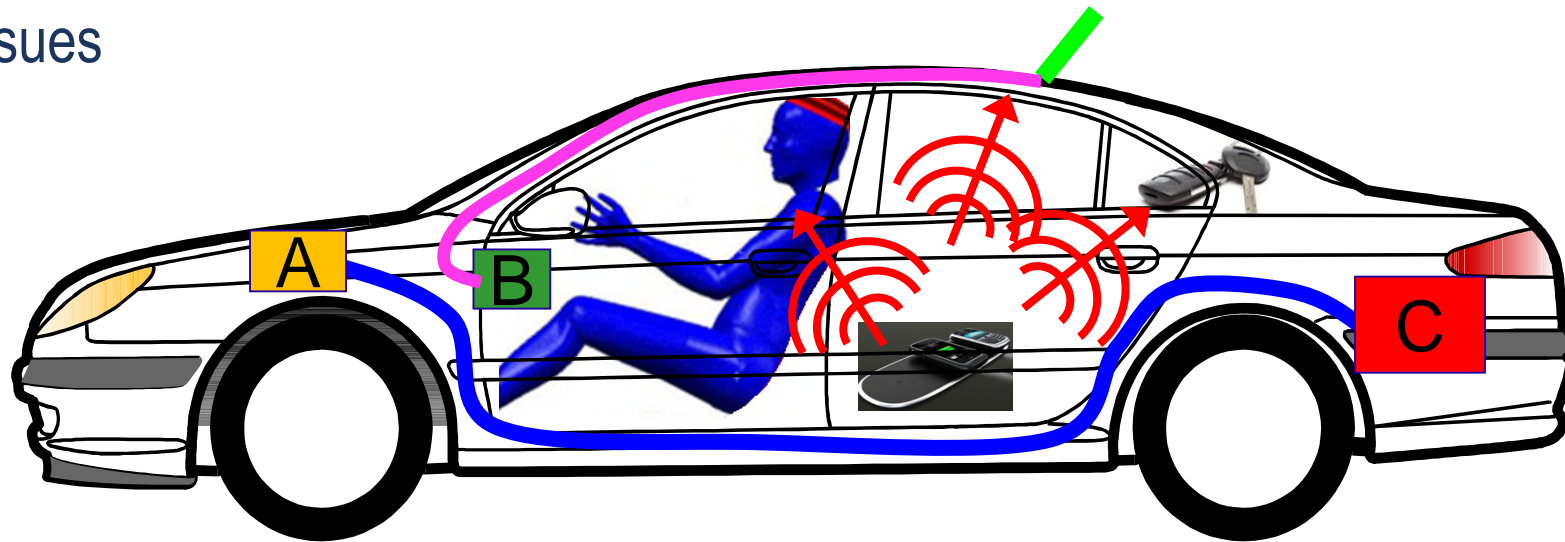

- Health protection
 - Human exposure to EM fields
- Risk of interference with systems sensitive to low frequency magnetic fields
 - Keyless entry & start system (typically using 125 kHz signals from ferrite antennas)
 - AM band radio reception
 - Embedded electronic devices in close vicinity to the source of the wireless charger: screens, radio, steering lock



Advanced Driver Assistance Systems (ADAS) and autonomous / automated vehicles

ADAS and autonomous / automated vehicles (1)

■ Description

- ADAS cover a **wide range of test cases** and of **complex driving configurations**
- Progressive introduction of **sophisticated functions** through iterative generations
- A **wide range of detection technologies**
 - LIDAR
 - Ultrasonic
 - Park assist
 - Self-parking
 - Sometimes: blind spot detection
 - **RADAR**
 - Vision (camera)
 - Lane departure warning
 - Rear park assist
 - Surrounding view monitor (« bird's eye view »)
 - Night vision and animal/human recognition
 - **Data fusion = RADAR + camera**
 - Pedestrian recognition and tracking



(www.hella.com)

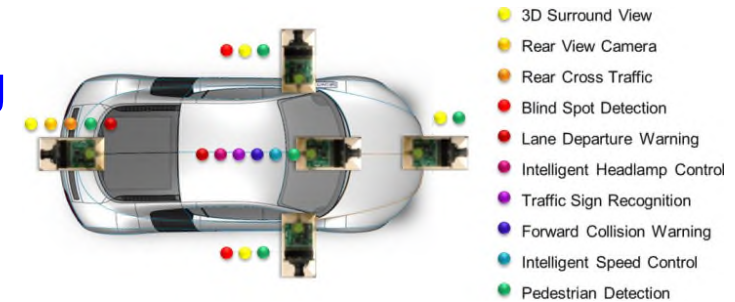

Advanced Driver Assistance Systems
(www.xilinx.com)

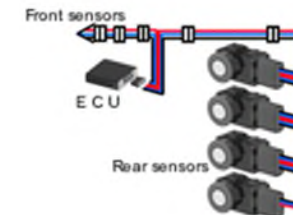

(www.globaldenso.com)



(www.nissan-global.com)

ADAS and autonomous / automated vehicles (2)

■ EMC issues

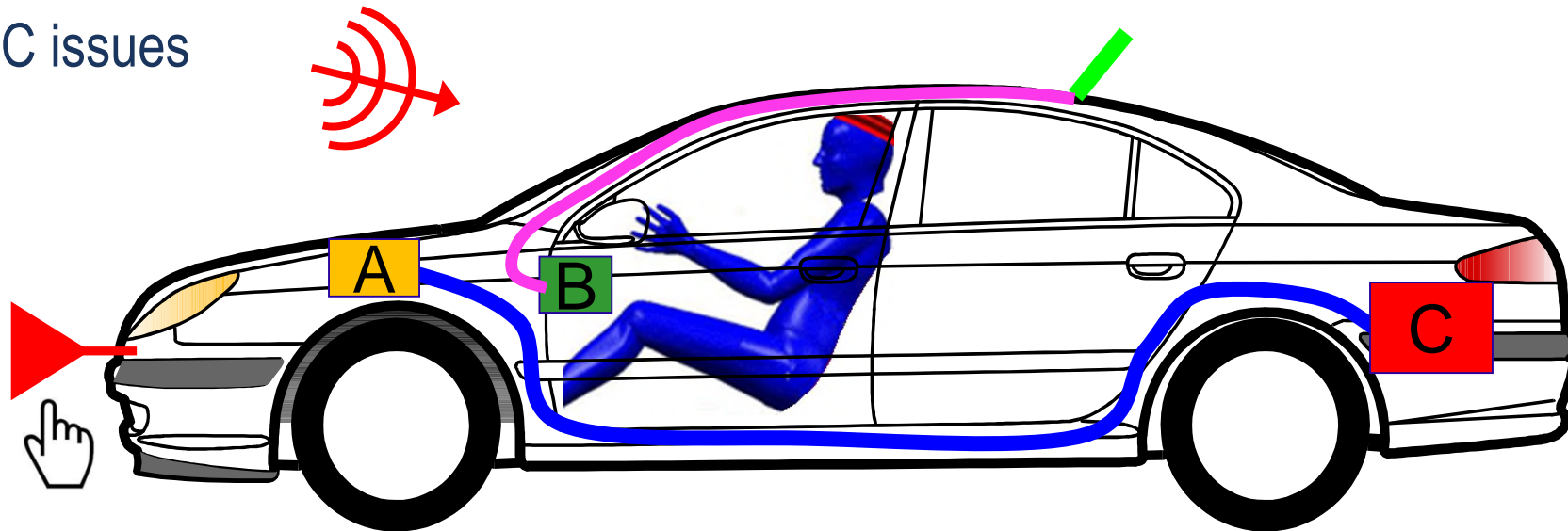

- Immunity of complex new systems involving safety functions
- EMC strongly included in the functional safety definition and concept
- EMC simultaneous failures on hardware, data and software redundancies shall be less than 10^{-9} to 10^{-11} failures per hour
- Immunity shall not only be ensured by validation tests, but also demonstrated at design level



Conclusions and perspectives

Conclusions and perspectives

- 3 very challenging future evolutions
 - Global warming and limited energy resources : PHEV, EV, 48V, composite materials, ...
 - Connected world : connected vehicles, RF cybersecurity, ...
 - Big cities and road traffic : autonomous / automated vehicle, safety issues, ...
- Increase of complexity
 - More functions and more interaction between functions
 - More communication links to the outside world (RF communications, vehicle charging)
- Increase in safety requirements
 - ADAS and autonomous / automated vehicle with safety targets 10^{-9} to 10^{-11} failures per hour
- Important challenges for EMC
 - Amend international standards and internal specifications with new requirements and tests
 - Ensure an earlier and even more robust EMC design (expert tools, simulation methodologies)
 - Develop new validation strategies (test methodology and facilities)
 - More connections with other domains (safety, RF communication, cybersecurity)
 - Increase EMC skills and knowledge for design and validation



Thank you for your attention

Abstract

- This presentation will focus on the numerous technical challenges awaiting the automotive industry in the near future. In this context, the speaker will describe the most important topics which raise serious and sometimes new EMC issues: battery electric vehicles (EVs) and full-hybrid electric vehicles (HEVs), mild-hybrid vehicles including a 48V power network, EVs and HEVs in the situation of charging mode, the special case of wireless inductive charging of EVs and HEVs, new materials and especially composite materials, new Digital Audio Broadcasting (DAB) reception, in-vehicle high data rate wire transmission links, wireless communication systems, in-vehicle wireless charging of mobile objects, and finally Advanced Driver Assistance Systems (ADAS) which are elementary bricks of future autonomous cars.